

AccuForce 12V - 75Ah | VRLA Battery



Applications

- Uninterruptible Power Supplies (UPS)
- Electric Power Systems (EPS)
- Emergency backup power supplies
- Electronic apparatus and equipment
- Communication power supplies
- DC power supplies
- Auto control system

Specifications

Nominal Voltage	12 V	
Number of cells	6	
Design Life	10 years	
Dimensions	Length	260 mm
	Width	168 mm
	Height	211 mm
	Total Height	214 mm
Approx. Weight	22.0 kg	
Nominal Capacity (25°C)	20 hours rate (3.94 A, 10.8 V)	78.8 Ah
	10 hours rate (7.50 A, 10.8 V)	75.0 Ah
	5 hours rate (13.10 A, 10.5 V)	65.5 Ah
	1 hour rate (46.50 A, 9.6 V)	46.5 Ah
Max. Discharge Current (25°C)	750 A (5s)	
Internal Resistance	6.0 mOhms	
Fully Charged battery (25°C)	3% of capacity declined per month at 20°C (average)	
Self-Discharge	Discharge : -15°C~50°C	
Operating Temperature Range	Charge	-10°C~50°C
	Storage	-20°C~50°C
	Short Circuit Current	2075 A
Charge Methods:	Cycle use	2.40-2.45 Vpc
	Maximum charging current	22.5 A
	Temperature compensation	-30 mV/°C
	Constant Voltage Charge (25°C)	Standby use
	Temperature compensation	-18 mV/°C

Battery Construction

Component	Positive Plate	Negative Plate	Container	Cover	Safety Valve	Terminal	Separator	Electrolyte
Raw material	Lead dioxide	Lead	ABS	ABS	Rubber	Copper	Fiberglass	Sulfuric acid

Dimensions

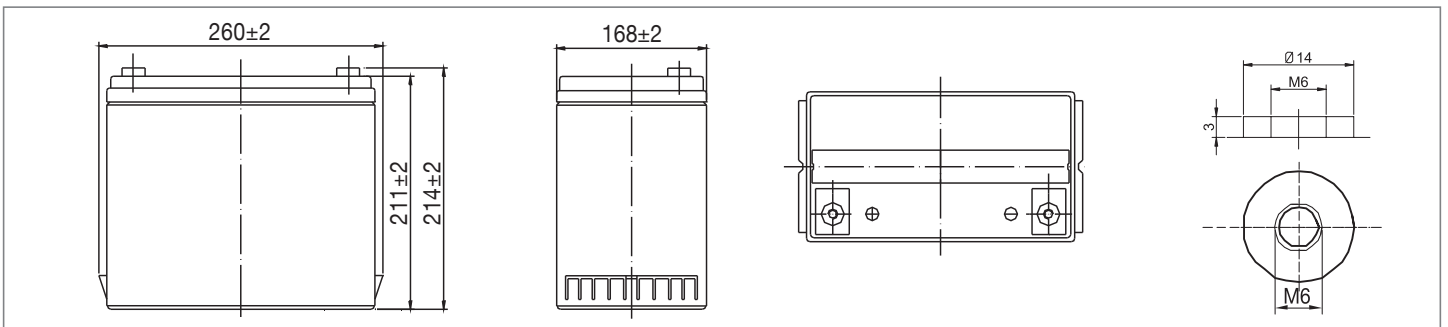

Constant Current Discharge (Amperes) at 25°C

End Voltage (Volts/Cell)	10min	15min	30min	1h	2h	3h	4h	5h	8h	10h	20h
1.60 V	158	124	75.0	46.5	27.4	19.1	15.7	13.4	9.18	7.64	4.01
1.65 V	153	121	73.5	45.8	27.2	19.0	15.6	13.3	9.13	7.62	4.00
1.70 V	146	116	71.3	44.6	27.0	18.9	15.5	13.2	9.06	7.60	3.99
1.75 V	140	112	69.5	43.8	26.6	18.8	15.4	13.1	9.00	7.55	3.97
1.80 V	132	106	67.0	42.4	25.9	18.2	14.9	12.7	8.73	7.50	3.94

Constant Power Discharge (Watts) at 25°C

End Voltage (Volts/Cell)	10min	15min	30min	1h	2h	3h	4h	5h	8h	10h	20h
1.60 V	1701	1359	842	530	317	225	184	158	109	91.2	48.1
1.65 V	1650	1326	825	522	315	224	183	157	108	91.0	48.0
1.70 V	1582	1277	799	509	313	222	182	156	108	90.7	47.9
1.75 V	1514	1234	780	499	308	221	181	155	107	90.2	47.6
1.80 V	1429	1169	751	483	300	214	175	150	104	89.6	47.3

(Note) The above characteristics data are average values obtained within three charge/discharge cycles not the minimum values.

AccuForce 12V - 75Ah | VRLA Battery

Temperature Effects on Float Life

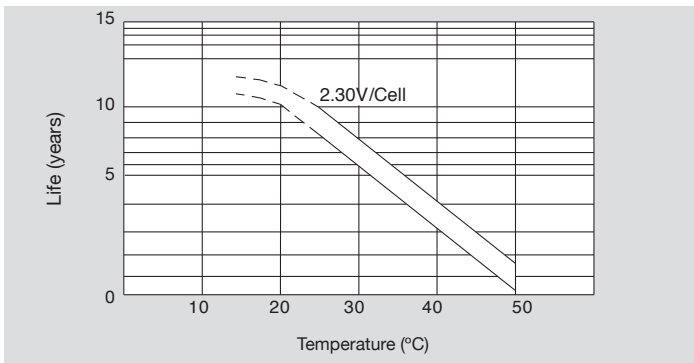

Self Discharge Characteristics

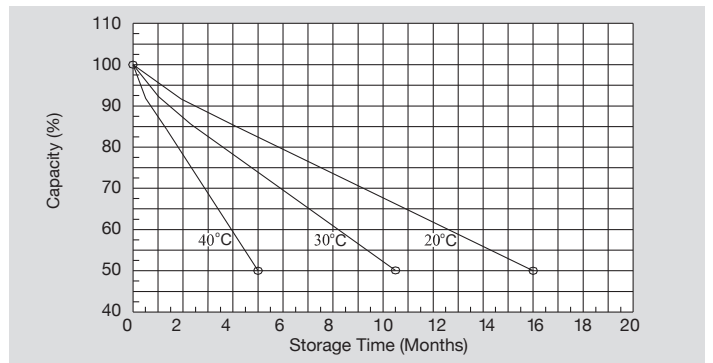

Discharge Characteristics (25°C)

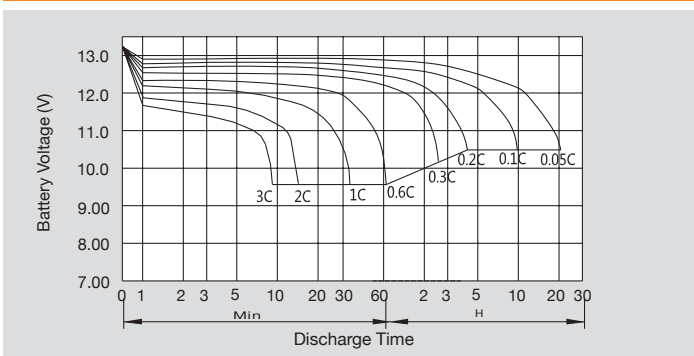

Constant Voltage Charging Characteristic (0.25 CA, 25°C)

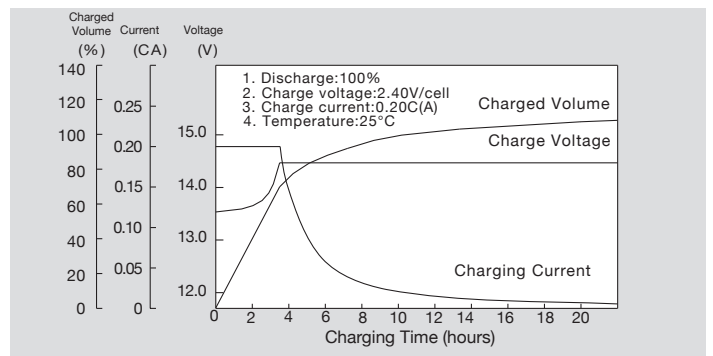

Relationship Between Charging Voltage and Temperature

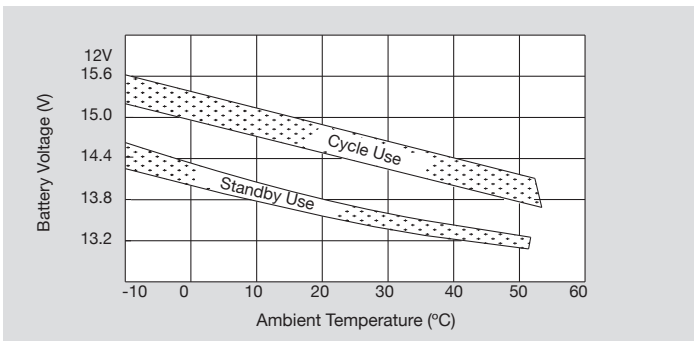

Relationship Between OCV and Residual Capacity (25°C)

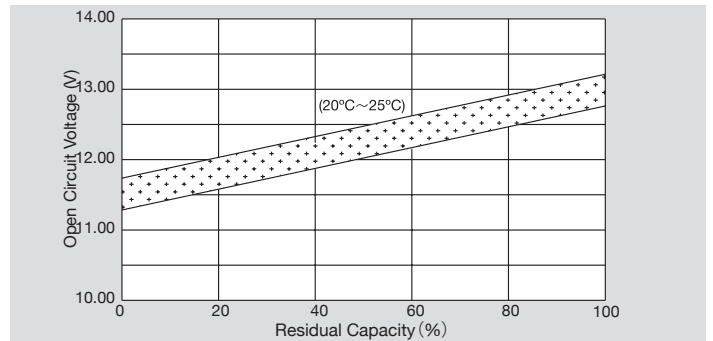

Cycle Service Life in Relation to Depth of Discharge

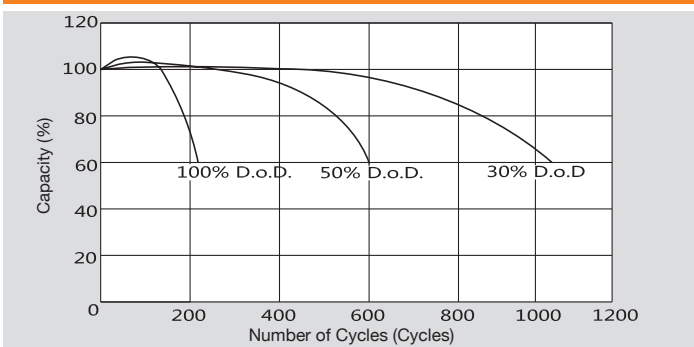

Temperature Effects on Capacity

