

# AccuForce 12V - 55Ah | VRLA Battery



## Applications

- Uninterruptible Power Supplies (UPS)
- Electric Power Systems (EPS)
- Emergency backup power supplies
- Electronic apparatus and equipment
- Communication power supplies
- DC power supplies
- Auto control system

## Specifications

Nominal Voltage	12 V	
Number of cells	6	
Design Life	10 years	
Dimensions	Length	229 mm
	Width	138 mm
	Height	208 mm
	Total Height	211 mm
Approx. Weight	15.3 kg	
	20 hours rate (2.89 A, 10.8 V)	57.80 Ah
Nominal Capacity (25°C)	10 hours rate (5.50 A, 10.8 V)	55.00 Ah
	5 hours rate (9.63 A, 10.5 V)	48.15 Ah
	1 hour rate (34.10 A, 9.6 V)	34.10 Ah
Max. Discharge Current (25°C)	550 A (5s)	
Internal Resistance	6.5 mOhms	
Fully Charged battery (25°C)	3% of capacity declined per month at 20°C (average)	
Self-Discharge	Discharge	-15°C~50°C
	Charge	-10°C~50°C
	Storage	-20°C~50°C
Operating Temperature Range	1512 A	
	Cycle use	2.40-2.45 Vpc
Charge Methods:	Maximum charging current	16.5 A
	Temperature compensation	-30 mV/°C
	Standby use	2.23-2.27 Vpc
	Temperature compensation	-18 mV/°C

## Battery Construction

Component	Positive Plate	Negative Plate	Container	Cover	Safety Valve	Terminal	Separator	Electrolyte
Raw material	Lead dioxide	Lead	ABS	ABS	Rubber	Copper	Fiberglass	Sulfuric acid

## Dimensions

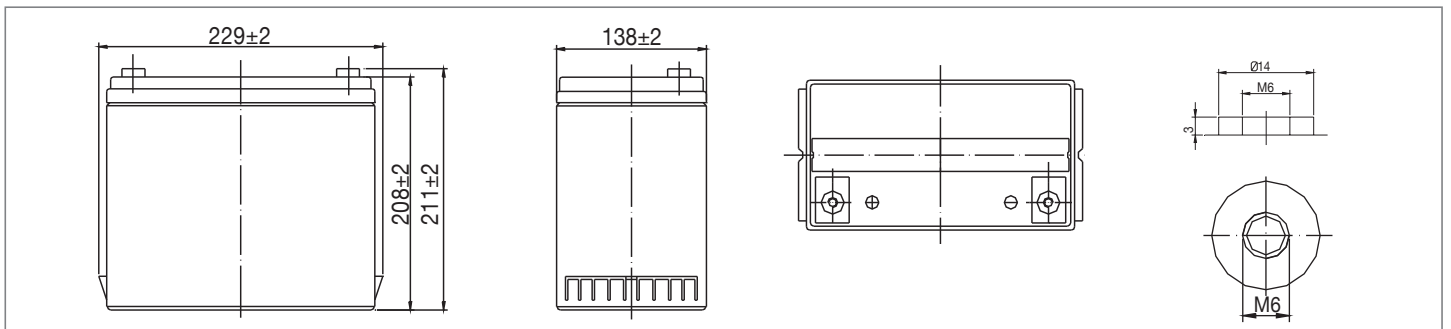

## Constant Current Discharge (Amperes) at 25°C

End Voltage (Volts/Cell)	10min	15min	30min	1h	2h	3h	4h	5h	8h	10h	20h
1.60 V	116	90.8	55.0	34.1	20.1	14.0	11.5	9.82	6.73	5.60	2.94
1.65 V	112	88.6	53.9	33.6	20.0	13.9	11.4	9.76	6.69	5.59	2.93
1.70 V	107	85.3	52.3	32.7	19.8	13.8	11.4	9.69	6.65	5.57	2.93
1.75 V	103	82.4	51.0	32.1	19.5	13.8	11.3	9.63	6.60	5.54	2.91
1.80 V	97.0	78.0	49.1	31.1	19.0	13.3	10.9	9.34	6.40	5.50	2.89

## Constant Power Discharge (Watts) at 25°C

End Voltage (Volts/Cell)	10min	15min	30min	1h	2h	3h	4h	5h	8h	10h	20h
1.60 V	1247	996	617	389	233	165	135	116	80.0	66.9	35.3
1.65 V	1210	973	605	383	231	164	134	115	79.5	66.7	35.2
1.70 V	1160	937	586	373	229	163	134	115	79.0	66.5	35.1
1.75 V	1110	905	572	366	226	162	133	114	78.4	66.1	34.9
1.80 V	1048	857	551	355	220	157	129	110	76.1	65.7	34.7

(Note) The above characteristics data are average values obtained within three charge/discharge cycles not the minimum values.

# AccuForce 12V - 55Ah | VRLA Battery

### Temperature Effects on Float Life

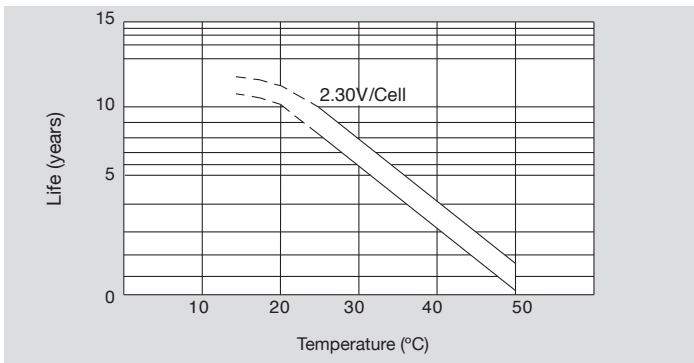

### Self Discharge Characteristics

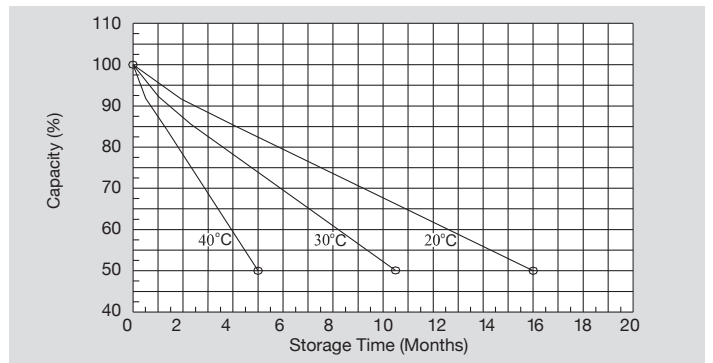

### Discharge Characteristics (25°C)

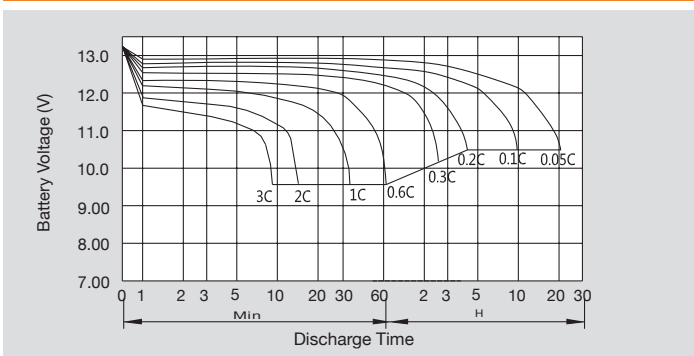

### Constant Voltage Charging Characteristic (0.25 CA, 25°C)

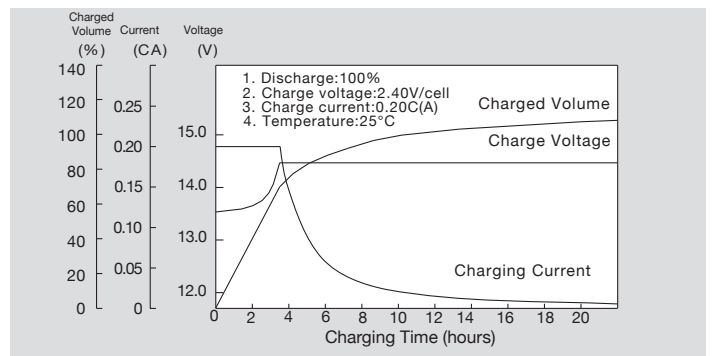

### Relationship Between Charging Voltage and Temperature

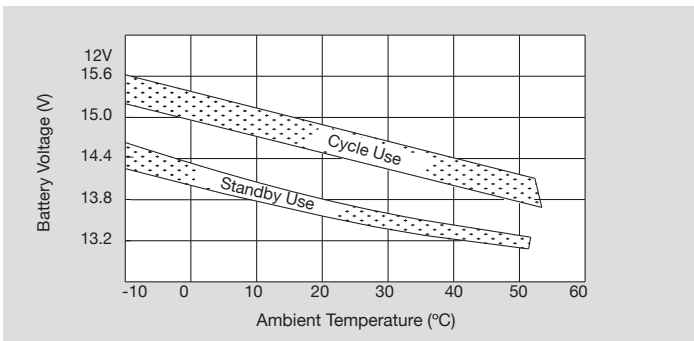

### Relationship Between OCV and Residual Capacity (25°C)

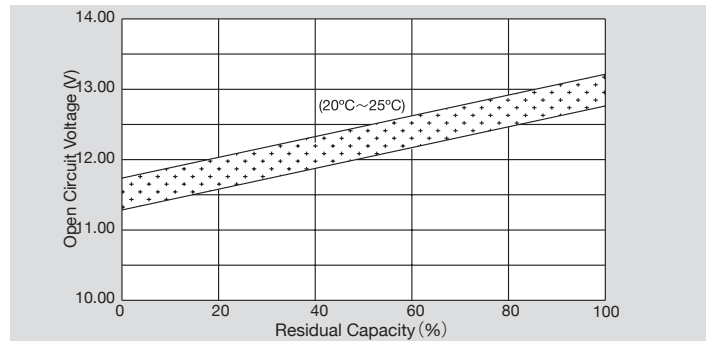

### Cycle Service Life in Relation to Depth of Discharge

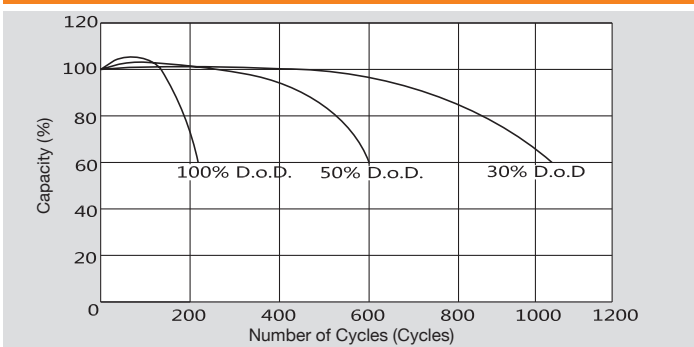

### Temperature Effects on Capacity

